

OpenRAN: A New Architecture for Mobile Wireless Internet Radio Access Networks

James Kempf, DoCoMo Communications Laboratories, USA
Parviz Yegani, Cisco Systems

ABSTRACT

Cellular telephony networks depend on an extensive wired network to provide access to the radio link. The wired network, called a radio access network, provides such functions as power control and, in CDMA networks, combination of soft handoff legs (also known as macrodiversity resolution) that require coordination between multiple radio base stations and multiple mobile terminals. Existing RAN architectures for cellular systems are based on a centralized radio network controller connected by point-to-point links with the radio base transceiver stations. The existing architecture is subject to a single point of failure if the RNC fails, and is difficult to expand because adding an RNC is expensive. Also, although a network operator may have multiple radio link protocols available, most RAN architectures treat each protocol separately and require a separate RAN control protocol for each. In this article we describe a new architecture, the OpenRAN architecture, based on a distributed processing model with a routed IP network as the underlying transport fabric. OpenRAN was developed by the Mobile Wireless Internet Forum IP in the RAN working group. The OpenRAN architecture applies principles to the radio access network that have been successful in reducing cost and increasing reliability in data communications networks. The result is an architecture that can serve as the basis for an integrated next-generation cellular radio access network.

INTRODUCTION

Cellular telephony networks depend on an extensive wired network between the core network and the radio transceivers that handle particular cells. This network, called a radio access network (RAN), provides functions that coordi-

nate access to the radio link between multiple radio base stations and between mobile terminals.

In this article we discuss a new architecture for mobile wireless RANs. The architecture, called the OpenRAN, is based on a distributed processing model with a routed IP network as the underlying transport fabric. The next section briefly discusses existing cellular RAN architectures and why a new architecture might be appropriate for fourth-generation (4G) cellular systems. We then present the principal requirements that drove the OpenRAN architectural design. In a later section the OpenRAN architecture is summarized. The architecture consists of a collection of 77 atomic functions grouped into 16 functional entities with 32 interfaces between them, so only a brief overview of the architecture is possible to present here. The full architecture is discussed in [1]. We then discuss future work on issues encountered during development of version 1 of the OpenRAN architecture. Finally, we summarize the article.

THIRD-GENERATION RAN ARCHITECTURES

Existing RANs are based on a star topology and a centralized architecture. A centralized radio network controller (RNC) is connected by point-to-point links with the radio base transceiver stations (BTSs) that handle radio network connectivity for a particular geographic region or cell (Fig. 1). RNCs are typically interconnected themselves to allow mobile nodes to roam between geographical areas controlled by different RNCs without requiring the participation of the core network in a handoff. As a mobile node roams between cells controlled by the same or an interconnected RNC, the RAN arranges for active voice or data sessions to be handed off between cells.

Permission to make digital or hard copies of all or part of this work for personal or classroom use is granted without fee provided that copies are not made or distributed for profit or commercial advantage and that copies bear this notice and the full citation on the first page. To copy otherwise, or republish, to post on servers, or to redistribute to lists requires prior specific permission and/or a fee.

In third-generation (3G) systems, the RNC is typically connected to a circuit-switched core for voice calls and circuit-switched data, and a packet-switched access gateway, for direct access to the Internet. If a mobile node roams beyond the area where RNCs are interconnected, a handoff through the core circuit-switched network or between packet-switched gateways is necessary. This architecture description is extremely generalized, and the two most prominent existing architectures (UTRAN [2] and IOS [3]) differ in details.

Although the 3G architecture has served well, there are a few potential problem areas:

- ¶The RNC is a single point of failure. If an RNC fails, an entire geographical region consisting of many cells is left without service.

- ¶Incrementally upgrading RAN capacity to handle more mobile terminals is sometimes not possible. If the number of cells exceeds the expansion limit of the RNC, an entirely new RNC must be bought, at great expense, even though only an incremental upgrade in bearer capacity is required.

- ¶Each radio link protocol has its own radio network layer protocol implemented by the RNC to control the radio link. Although there are many functions peculiar to the radio link protocol, some functions, such as mobility management, are common and could be handled by IP protocols such as routing. Spectrum management is hindered by the lack of commonality in handling common functions.

- ¶Because the RAN/core interfaces were originally designed for connection to a circuit-switched core, the interface between the RAN and IP-based networks requires a heavyweight gateway. In 4G cellular networks, where the core network is based on IP, such gateways may become a performance or complexity bottleneck.

These potential problem areas led to the design of the OpenRAN architecture.

OPENRAN REQUIREMENTS

The OpenRAN requirements were formulated as part of the Mobile Wireless Internet Forum's (MWIF's) OpenRAN design, undertaken by the IP in the RAN working group. The requirements were developed in consultation with mobile operators who also participate in MWIF, and they reflect the MWIF operators' requirements for a next-generation RAN design.

ARCHITECTURAL REQUIREMENTS

The architectural requirements for OpenRAN originated out of a desire for improvement over the current centralized 3G RAN architectures. The following are a few of the key architectural requirements:

- ¶Because no change in radio link protocols is anticipated, the architecture must support existing multiple radio technologies, in particular, the existing 2G and 3G radio technologies (e.g., wCDMA and cdma2000), but also wireless LANs. The architecture should also be flexible enough to accommodate new radio link protocols.

- ¶To facilitate cost-effective scaling as the number of mobile nodes and the bearer traffic they generate increase, the architecture must support separate and distributed control and

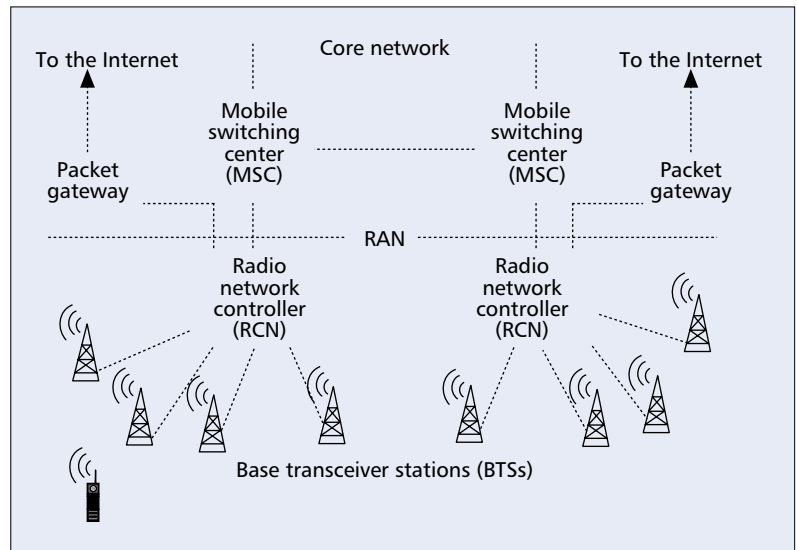

■ Figure 1. Third-generation RAN architecture.

bearer paths on the core network side of the RAN. On the radio side of the RAN, control and bearer separation becomes less important because existing radio protocols often mix control and bearer traffic on one channel.

- ¶To facilitate cost-effective scaling of cell functions vs. mobile terminal functions, the architecture must support separate and distributed cell and mobile node control and bearer functions.

- ¶Because radio spectrum is costly and bandwidth-constrained, radio links are effectively underprovisioned from a networking standpoint and require particular attention to quality of service (QoS). The architecture must support multiple QoS levels in handoff scenarios, in addition to end-to-end QoS and the ability to dynamically change QoS while a session is in progress. QoS on the wire in the RAN and over the air must be integrated.

- ¶To provide maximum deployment flexibility of the wired network, the architecture must support IP as the base layer for both control and bearer transport.

- ¶Because network management is the area with the highest lack of interoperability between RAN vendors in current 3G RAN architectures, the architecture must support operation, administration, and network management based on open interfaces and Internet Engineering Task Force (IETF) network management protocols.

- ¶Since IP core networks are anticipated to be widespread in 4G, the architecture must support optimal connection with IP-based core network architectures.

OPERATOR AND SERVICE REQUIREMENTS

A collection of operator and service requirements were developed based on what operators perceived as important. A few key requirements are the following:

- ¶The architecture must support open interfaces between network entities, with IETF protocols wherever possible. Open interfaces are desirable to support an open interoperable market in equipment from vendors, similar to the situation in the datacom networking area.

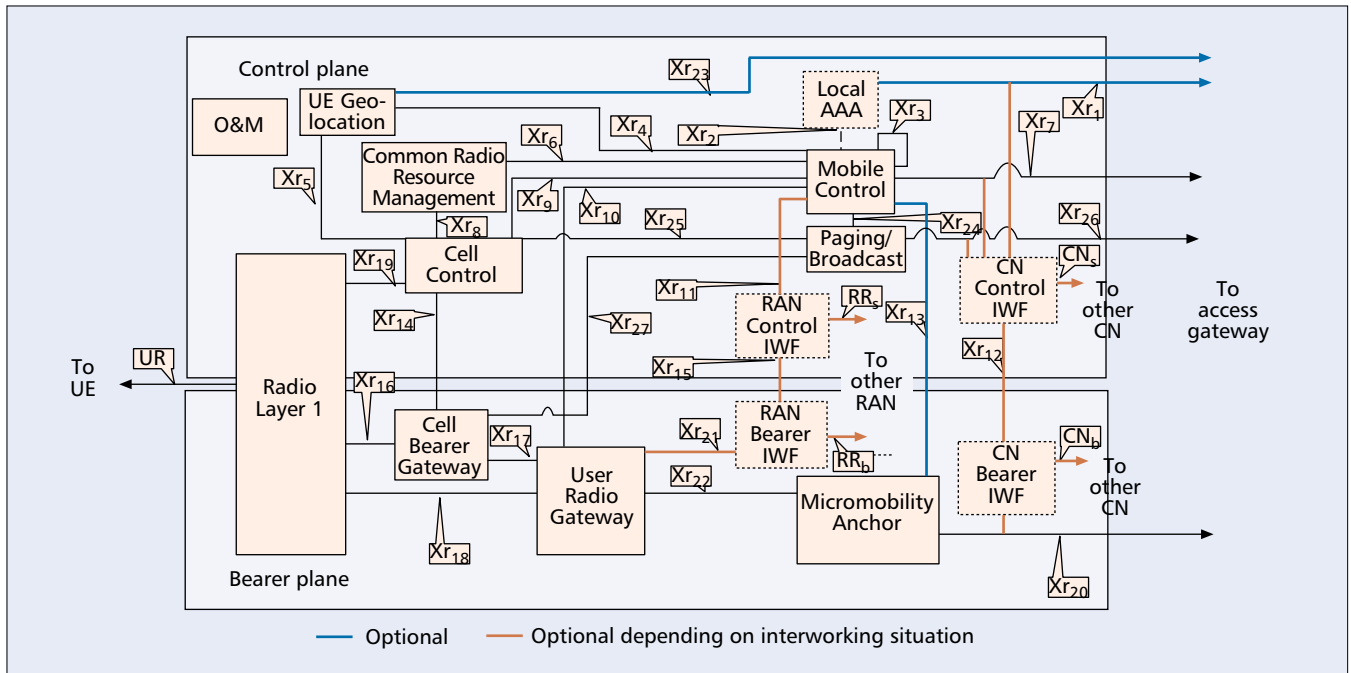

■ **Figure 2.** OpenRAN architecture.

¶The architecture must support interoperability with 2G/3G core networks, and with 2G/3G access networks if those access networks are running the same radio link protocol. No interoperability is required with access networks that are running different radio link protocols.

¶In order to facilitate deployment of distributed OpenRAN components, the architecture must support easy installation and configuration by allowing components to auto-configure wherever possible.

¶To maximize the ability of operators to manage usage of spectrum assets, the architecture must allow handoff between different radio link protocols on a single RAN. An example is a handoff between the Global System for Mobile Communications (GSM) and wideband code-division multiple access (WCDMA).

OPENRAN ARCHITECTURE

The OpenRAN architecture was developed by partitioning a RAN into atomic functions, then grouping the atomic functions into functional entities based on the requirements. Interfaces between the functional entities were then identified, and the nature of the traffic over those interfaces was characterized as a first step toward possible protocol development on those interfaces that are declared open. The following subsections describe the functional entities, separated into control and bearer planes. The radio layer 1 functions, and the operations, administration, and management functions were kept separate because they span control and bearer. Transport functional entities were also developed, but were not included in the architecture because they are described more completely in a separate report devoted exclusively to the problem of using IP transport in RANs [4]. Figure 2 contains an illustration of the archi-

ture, including numbered interfaces between the functional entities.

CONTROL PLANE FUNCTIONAL ENTITIES

Control plane functional entities are involved in controlling the radio link protocol between the mobile terminals and the BTSs. The following subsections describe the control plane functional entities.

Cell Control: The Cell Control functional entity is responsible for all control functions associated with the cell. These functions include allocation of common cell physical and logical radio resources, admission and congestion control, system information broadcast, dynamic channel allocation, and downlink open loop power control. The Cell Control functional entity also executes paging on common paging channels in response to a command from the Paging/Broadcast functional entity.

Mobile Control: The Mobile Control functional entity is responsible for all control functions associated with a particular mobile terminal. Functions involved in coordination of a mobile's access to the radio network are one area managed by Mobile Control, including allocation of physical and logical radio resources dedicated to a particular mobile terminal, coordination of admission control for allowing a new mobile terminal into the network, and setting up and releasing radio connections. Another area is coordination involved in maintaining a mobile's connection with the RAN, including admission control on packets to the radio network, management of the radio resource context recording the mobile's resource allocations, and uplink outer loop and downlink outer loop power control. The Mobile Control functional entity also handles mapping of QoS between the radio and wired parts of the network, and such diagnostic functions as

tracing a mobile terminal's activity and measurement of the MAC layer for diagnostic and administrative purposes. Paging of the mobile on dedicated (as opposed to common) channels is also handled by the Mobile Control function, although the Paging/Broadcast functional entity controls paging overall.

The Mobile Control function also plays a big role in handover. The Mobile Control handles both soft and hard handover, changing the BTSs with which the mobile is in communication in response to changes in QoS and network load. In CDMA systems, Mobile Control is responsible for controlling combining and splitting of soft handoff legs, or macrodiversity resolution, although the process of actually performing the macrodiversity resolution is handled by the User Radio Gateway (see below). Should a mobile's communication line become so stretched that a relocation of the Mobile Control function or User Radio Gateway function is necessary, the Mobile Control function also controls relocation of the old Mobile Control and/or User Radio Gateway dedicated to that mobile to a new Mobile Control and/or User Radio Gateway.

UE Geo-location: The UE Geo-location functional entity collects geographic location data from the geo-position information generation function in the Radio Layer 1 function or by querying the mobile terminal and calculates the geographic location. The information is then forwarded on either the Mobile Control function or the core network.

Common Radio Resource Management: The Common Radio Resource Management functional entity collects radio channel quality estimates on both the dedicated and common channels for purposes of load balancing. It also signals a request for handover for purposes of load balancing, path optimization, and resource optimization, using information from the Mobile Control function.

Paging/Broadcast: The Paging/Broadcast functional entity coordinates alerting mobile terminals in response to a paging message from the core network. An important part of this function is determining whether the mobile terminal has an active context or is in dormant mode. If the mobile terminal has an active context, the Mobile Control function is informed so that paging can be done over a dedicated channel. If no active context is available, the Cell Control function performs the page over a common channel. The function also controls broadcast/multicast between the core network and the RAN.

Interworking: Two control interworking functions are included in the OpenRAN architecture: Core Network Control Interworking and RAN Control Interworking. Core Network Control Interworking handles control interactions between the OpenRAN and legacy Signaling System No. 7 (SS7)-based core networks. RAN Control Interworking handles control interactions between the OpenRAN and legacy 3G RANs that support the same radio protocol. The OpenRAN architecture is not intended to support control interworking with a legacy RAN using a different radio link protocol.

BEARER PLANE FUNCTIONAL ENTITIES

Bearer plane functional entities are involved in adapting application IP traffic to the radio in both the uplink and downlink directions. The following subsections describe the bearer plane functional entities.

User Radio Gateway: The User Radio Gateway functional entity is primarily responsible for adapting application IP traffic to the radio. The adaptation involves segmenting IP packets into radio frames on the downlink and reassembling radio frames into IP packets on the uplink. This function is performed for all channels, both common and dedicated. In CDMA systems, the User Radio Gateway does macrodiversity resolution. Dedicated control traffic from the Mobile Control to the mobile terminal is multiplexed onto the dedicated control channels at the User Radio Gateway. The User Radio Gateway also performs such functions as uplink outer loop power control, header compression, and radio link encryption and decryption (to the extent this is not handled by the Radio Layer 1 function). If the User Radio Gateway function for a particular mobile must be relocated, the old User Radio Gateway assists in the relocation.

Cell Bearer Gateway: The Cell Bearer Gateway functional entity is responsible for managing common channel access. The Cell Bearer Gateway handles multiplexing of common channel control and bearer traffic, and performs broadcast/multicast. Segmentation/reassembly for the common channels is not performed by the Cell Bearer Gateway, but is handled by the User Radio Gateway.

Micromobility Anchor: The Micromobility Anchor functional entity is responsible for adapting between inter-RAN core network macro-mobility and intra-RAN micromobility. If intra-RAN micromobility is handled by an IP transport protocol (e.g., routing), this functional entity might not be needed, and it has been included in the architecture for further study.

Interworking: Two bearer interworking functions are included in the OpenRAN architecture: Core Network Bearer Interworking and RAN Bearer Interworking. Core Network Bearer Interworking handles application traffic between the OpenRAN and legacy asynchronous transfer mode (ATM)/DSO-based networks. RAN Bearer Interworking handles bearer interactions between the OpenRAN and legacy 3G RANs that support the same radio protocol. The OpenRAN architecture is not intended to support bearer interworking with a legacy RAN using a different radio link protocol.

RADIO LAYER 1

Functions involved in controlling radio layer 1 were collected into the Radio Layer 1 functional entity. System information broadcast, such as the pilot channel in CDMA systems, and certain power control functions, such as uplink outer loop power measurement, downlink outer loop power control, and uplink inner loop power control, are performed by Radio Layer 1. Initial detection and establishment of contact with a mobile terminal is also handled by Radio Layer 1.

To maximize the ability of operators to manage usage of spectrum assets, the architecture must allow handoff between different radio link protocols on a single RAN. An example is a handoff between GSM and WCDMA.

Although not part of the OpenRAN, the Access Gateway handles traffic between the OpenRAN and an IP core network. The Access Gateway does not handle traffic between the OpenRAN and legacy core networks; the Core Network Interworking functions are responsible for that function.

OPERATIONS, ADMINISTRATION, AND MANAGEMENT

The initial OpenRAN study did not identify a complete set of operations, administration, and management functions, but a few were called out. Identified operations, administration, and management functions are:

- Static configuration and allocation of common radio resources
- Configuration of system information broadcast
- Management of IP address assignment in the RAN
- Radio network operations and maintenance
- Database management
- Tracing control

Interoperable RAN management using IP protocols such as Simple Network Management Protocol (SNMP) [5] was identified as an important part of the OpenRAN architecture, although work on defining interoperable management was deferred.

ACCESS GATEWAY

Although not part of the OpenRAN, the Access Gateway handles traffic between the OpenRAN and an IP core network. The Access Gateway does not handle traffic between the OpenRAN and legacy core networks; the Core Network Interworking functions are responsible for that.

The Access Gateway's primary functions are to handle admission control and QoS. The Access Gateway is responsible for performing authorization and authentication to admit IP packet flows between the core and RAN. The Access Gateway maps QoS classifications on incoming and outgoing application packets between the RAN and the core. It is not directly responsible for managing radio QoS, which is handled by the Mobile Control function, but as part of the admission control function it forwards a request for RAN QoS coming from the core to the Mobile Control function to perform radio QoS, and, in the reverse direction forwards a request for core QoS to the appropriate bandwidth request manager in the core. QoS policing and accounting is also performed on packet flows between the core and RAN.

The Access Gateway also has a few other functions. The Access Gateway may be involved in providing firewall service if the core and RAN are in separate administrative domains. The Access Gateway is additionally responsible for coordinating between the Micromobility Anchor and the core network macromobility manager to perform inter-RAN mobility. Depending on the core and mobile terminal support for dormant mode and paging, the Access Gateway may be involved in coordinating inter-RAN movement of dormant mode mobile terminals and paging.

FUTURE WORK

The focus in version 1 of the OpenRAN architecture has been on identifying the radio-specific atomic functions of the RAN and grouping them into functional entities that can be implemented as a distributed system. The working group is

currently working on mechanisms for pushing mobility management, QoS, and security/AAA from the radio network layer into the transport layer, where they would be common across all supported radio link protocols.

A common radio network layer protocol for multiple radio link protocols was identified as another area for future work. Having a common radio network layer protocol for controlling multiple radio link protocols facilitates pushing mobility management, QoS, and security/AAA to the transport layer, and in addition simplifies inter-radio link protocol handoff, allowing network operators to optimize use of spectrum assets. However, there are questions about how broad such a protocol can be, given the diversity in channel structures and other features of existing radio link protocols.

A crucial issue for the OpenRAN is operations, administration, and management. A major problem with existing RANs is that these areas are not standardized, so it is difficult to achieve interoperability even in systems such as UTRAN [2] where the protocols and interfaces are standardized. RANs require more and different kinds of network management than standard IP-based wired networks, but IP-based network management protocols seem general enough for the task.

Finally, as a practical matter, network operators wishing to deploy the OpenRAN require a blueprint for interoperability and deployment with their existing infrastructure. Most operators won't be deploying new networks from scratch, but rather gradually replacing existing networks as their operational lifetime comes to a close, or as the expense of operating them becomes more than the expected expense of replacing them with newer, less expensive gear. Although the OpenRAN architecture has provision for interoperability, the details remain to be worked out.

SUMMARY

The OpenRAN architecture presented in this article is a first step toward an all-IP radio access network. The architecture as it currently stands describes how to decompose radio access network functionality in a way that allows a distributed implementation and opens the door to implementing functions common among multiple radio link protocols, namely mobility management, QoS, and security/AAA, at the transport layer instead of in separate radio network layer protocols. There is still much work to be done on key issues involving how to implement common functions and on a common radio network layer protocol, and on interoperable network management.

ACKNOWLEDGMENTS

The OpenRAN architecture is the product of the MWIF IP in the RAN working group. Special thanks go to Eddie Troch and Helmut Becker of Siemens, Ulrich Barth and Ralph Single of Alcatel, Fabio Longoni of Nokia, Yuchirio Hamamoto of Fujitsu, Goran Janevski of Nortel, Gino Scribano of Motorola, Shinichi Baba of Toshiba, and HoGeun Lee of Samsung for their dedicated participation in the OpenRAN design. Without their work, the OpenRAN architecture

would never have happened. Thanks are also given to 3Gwireless 2002 by Delson Group (<http://www.delson.org>).

REFERENCES

- [1] "OpenRAN Architecture in 3rd Generation Mobile Systems," MTR007v1, MWIF tech. rep., May 2001; http://www.mwif.org/technical_report.html
- [2] TS 25.401 v3.3.0, R-99, RAN WG3, "UTRAN Overall Description," 3GPP, 1999; <http://www.3gpp.org>
- [3] CDG-IOS v. 3.1.1, CDMA Development Group, "MSC to BS Interface Inter-Operability Specification." June 1999.
- [4] "IP in the RAN as a Transport Option in 3rd Generation Mobile Systems," MTR006v2, MWIF tech. report, May 2001; http://www.mwif.org/technical_report.html.
- [5] J. Case *et al.*, "Simple Network Management Protocol (SNMP)," STD0015 (RFC 1157), May 1990; <http://ftp.isi.edu/in-notes/rfc1157.txt>.

BIOGRAPHIES

JAMES KEMPF (kempf@docomolabs-usa.com) graduated from the University of Arizona with a Ph.D. in systems engineering, computer science minor, in 1984. He worked at Hewlett-Packard Laboratories in the late 1980s on object-oriented programming languages and systems, and at Sun Microsystems from 1988 until 2001 on object-oriented operating systems and wireless networking. Currently he is a research fellow at DoCoMo Communications Laboratories USA researching 4G all-IP cellular networks. He is also co-chair of the IETF Seamoby (Seamless Mobility) working group and a member of the Internet Architecture Board.

PARVIZ YEGANI (pyegani@cisco.com) received his Ph.D. degree (with high honors) from the School of Electrical Engineering at Purdue University in December 1989. In January 1990 he joined the faculty of the Department of Electrical Engineer-

ing at State University of New York at Stony Brook. In September 1990 he moved to the IBM Networking Division in Research Triangle Park, North Carolina. While at IBM, as a member of the core network architecture team, he was involved in many projects including IBM fast-packet switched networks architecture and wireless multimedia communications networks standards. During his tenure at IBM he was IBM's liaison to Columbia University and an advisory board member to the Communications Research Center at North Carolina State University. He also served as a research adjunct professor of the Computer Science Department at Michigan State University where he assisted in establishing an advanced research laboratory on high-speed ATM networks and supervised thesis research for several Ph.D. students. In July 1994 he moved to QUALCOMM where he participated in several key projects focusing on CDMA systems design, architecture, and standards. He was one of the main contributors to the enhancement of the CDMA air-interface signaling protocol and access network standards. This resulted in publication of several CDMA 2.5G/3G core standards such as IS-95-A/B, IS-634-B, IS-2000 and IS-2001. In August 1999, he moved to Ericsson where he continued his role in leading wireless access network standards. As the co-chair of the architecture group in TSG-A 3GPP2 he led an effort to develop the packet data architecture for cdma2000 systems. This resulted in publication of a family of the 3G IOS standards. In February 2000, he joined Cisco Systems where he is currently a technical leader of the Mobile Wireless Group and a leading member of the Mobile Systems Architectures and Standards Group. He is currently chair of the IP-in-the-RAN working group (WG) of the MWIF, where he is leading an industry-wide effort to define an IP-based Open Radio Access Network Architecture. He is also involved in standards activities in TIA, 3GPP2 and IETF. He was previously the chair of the All-IP Ad Hoc group and is currently the vice chair of the 3G access network architecture working group in TSG-A/3GPP2. His research interests include IP routing and switching, mobile wireless network architectures and protocols and high-speed communications networks.

The working group is currently working on mechanisms for pushing mobility management, QoS, and security/AAA from the radio network layer into the transport layer, where they would be common across all supported radio link protocols.